



Visualisation; Diagnostics

Easy to Configure

Programming IEC 61131-3

Rapid Installation

## SDD ES ETH

**PILZ**  
THE SPIRIT OF SAFETY

► PSEN sensor technology

This document is the original document.

All rights to this documentation are reserved by Pilz GmbH & Co. KG. Copies may be made for the user's internal purposes. Suggestions and comments for improving this documentation will be gratefully received.

Source code from third-party manufacturers or open source software has been used for some components. The relevant licence information is available on the Internet on the Pilz homepage.

Pilz®, PIT®, PMI®, PNOZ®, Primo®, PSEN®, PSS®, PVIS®, SafetyBUS p®, SafetyEYE®, SafetyNET p®, the spirit of safety® are registered and protected trademarks of Pilz GmbH & Co. KG in some countries.



SD means Secure Digital

<b>Introduction</b> .....	<b>5</b>
Validity of documentation .....	5
Using the documentation .....	5
Definition of symbols .....	5
<b>Overview</b> .....	<b>6</b>
Scope of supply .....	6
Unit features .....	6
Front view .....	7
<b>Safety</b> .....	<b>8</b>
Intended use .....	8
Safety regulations .....	9
Additional documents that apply .....	9
Use of qualified personnel .....	9
Warranty and liability .....	9
Disposal .....	9
<b>Security</b> .....	<b>10</b>
Implemented security measures .....	10
Required security measures .....	10
<b>Function description</b> .....	<b>11</b>
Operation .....	11
Data structure .....	12
Block diagram .....	12
<b>Installation</b> .....	<b>13</b>
<b>Commissioning</b> .....	<b>13</b>
General wiring guidelines .....	13
Ethernet interfaces .....	13
RJ45 interfaces ("Ethernet") .....	13
Requirements of the connection cable and connector .....	14
Interface configuration .....	14
RJ45 connection cable .....	14
Process data exchange .....	15
System structure .....	16
Set IP address .....	16
<b>Operation</b> .....	<b>17</b>
Display .....	18
Structure .....	18
Operate menu .....	19
Menu structure .....	19
Menu settings .....	20
Device History menu .....	21
Device Info menu .....	22

Device Event menu .....	23
Web server .....	23
Events of Safety Device Diagnostics .....	28
<b>Dimensions in mm .....</b>	<b>30</b>
<b>Tecnicl details .....</b>	<b>32</b>
<b>Supplementary data .....</b>	<b>34</b>
Network data .....	34
<b>Order reference .....</b>	<b>34</b>
Product .....	34
Accessories .....	34
<b>EC declaration of conformity .....</b>	<b>35</b>

## Introduction

### Validity of documentation

This documentation is valid for the product SDD ES ETH. It is valid until new documentation is published.

This operating manual explains the function and operation, describes the installation and provides guidelines on how to connect the product.

### Using the documentation

This document is intended for instruction. Only install and commission the product if you have read and understood this document. The document should be retained for future reference.

### Definition of symbols

Information that is particularly important is identified as follows:



#### **DANGER!**

This warning must be heeded! It warns of a hazardous situation that poses an immediate threat of serious injury and death and indicates preventive measures that can be taken.



#### **WARNING!**

This warning must be heeded! It warns of a hazardous situation that could lead to serious injury and death and indicates preventive measures that can be taken.



#### **CAUTION!**

This refers to a hazard that can lead to a less serious or minor injury plus material damage, and also provides information on preventive measures that can be taken.



#### **NOTICE**

This describes a situation in which the product or devices could be damaged and also provides information on preventive measures that can be taken. It also highlights areas within the text that are of particular importance.



## INFORMATION

This gives advice on applications and provides information on special features.

## Overview

### Scope of supply

- ▶ Fieldbus module SDD ES ETH

### Unit features

SDD ES ETH is an active subscriber (Master) of Safety Device Diagnostics

- ▶ Backlit display
- ▶ LEDs for
  - Supply voltage
  - Fieldbus interface
  - Safety states and diagnostic information for the safety devices
  - Error
- ▶ Multifunction switch for menu control
- ▶ Plug-in connection terminals:  
Either spring-loaded terminal or screw terminal available as an accessory (see Order references for accessories).
- ▶ 6 contacts that can be used as input contacts and/or output contacts (GPIO)

## Front view

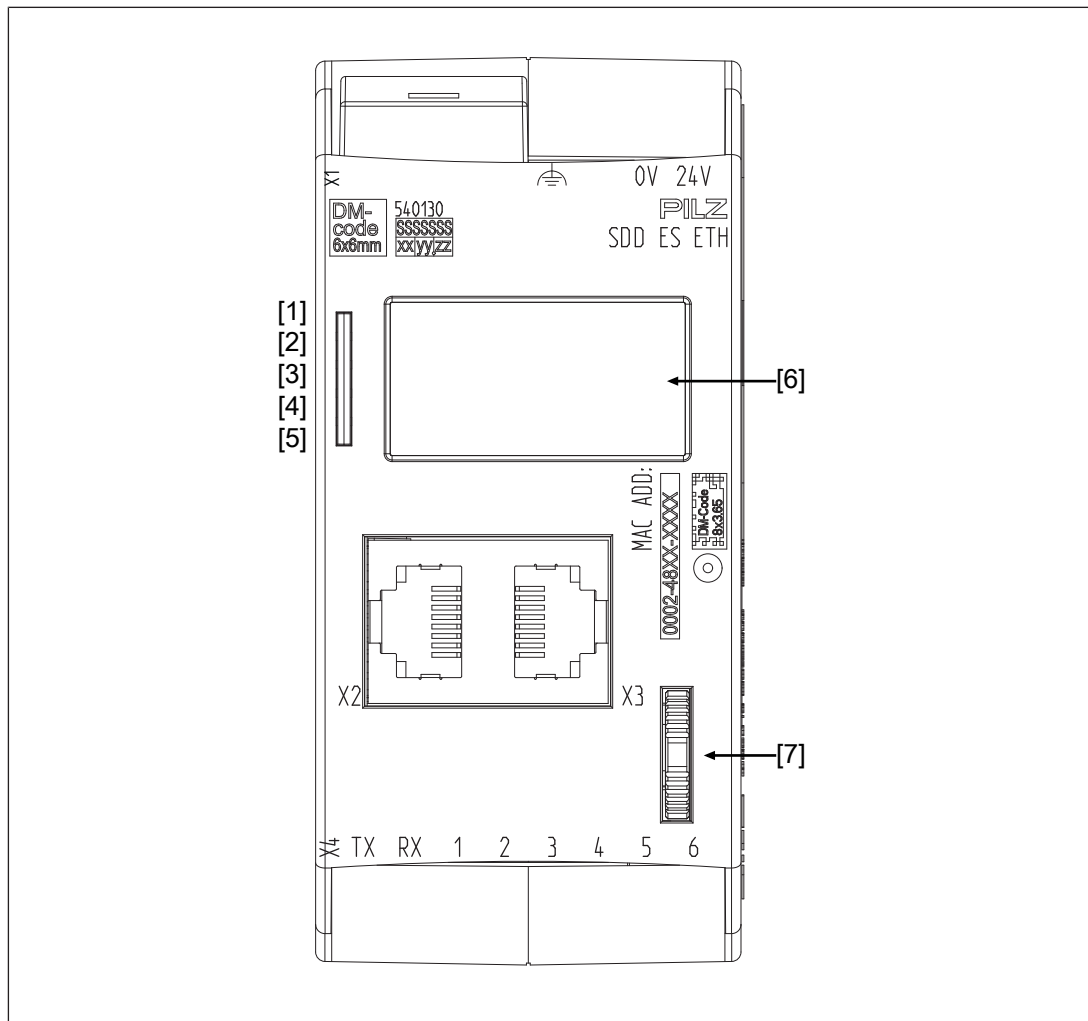

## Legend

- X1 ▶ Supply voltage 0 V, 24 V
  - ▶ Functional earth
- X2/X3 Ethernet interfaces
- X4 ▶ TX: Output for connecting the signal input of the safety devices
  - ▶ RX: Input for connecting the signal output of the safety devices
  - ▶ 1 – 6: Configurable inputs/outputs for connecting signal inputs/outputs from additional devices (not incorporated in safety device diagnostics)
- [1] LED Power
- [2] LED ModbusTCP
- [3] LED Devices
- [4] LED Start up
- [5] LED Fault
- [6] Display
- [7] Multifunction switch

## Safety

### Intended use

The SDD ES ETH is used for communication between connected safety devices and the Modbus/TCP. The Modbus/TCP is designed for data exchange at field level. The SDD ES ETH operates as the Server; a connected control system operates as the Client.

Application of the product SDD ES ETH:

- ▶ Evaluate and display diagnostic data and status information from safety devices
- ▶ Connect safety devices and Modbus/TCP
- ▶ Processing and display of safety device data
- ▶ Transfer diagnostic data and status information from the safety devices to Modbus/TCP

Appropriate safety devices are listed in the document "System Description Safety Device Diagnostics".

The SDD ES ETH may not be used for safety-related functions.

Safety-related functions of the safety devices have to be evaluated separately by a safe evaluation device.

The following is deemed improper use in particular

- ▶ Any component, technical or electrical modification to the product,
- ▶ Use of the product outside the areas described in this manual,
- ▶ Use of the product outside the technical details (see [Technical details](#)  32]).



### NOTICE

#### EMC-compliant electrical installation

The product is designed for use in an industrial environment. The product may cause interference if installed in other environments. If installed in other environments, measures should be taken to comply with the applicable standards and directives for the respective installation site with regard to interference.

## Safety regulations

### Additional documents that apply

Please read and take note of the following documents:

- ▶ Operating manual for the relevant Pilz safety device
- ▶ Operating manual of a passive junction, for example:
  - PSEN ix2 F4 code
  - PSEN ix2 F8 code
  - PDP67 F 4 code
  - PSEN Y junction
- ▶ System description "Safety Device Diagnostics"

You will need to be conversant with the information in these documents in order to fully understand this operating manual.

### Use of qualified personnel

The products may only be assembled, installed, programmed, commissioned, operated, maintained and decommissioned by competent persons.

A competent person is a qualified and knowledgeable person who, because of their training, experience and current professional activity, has the specialist knowledge required. To be able to inspect, assess and operate devices, systems and machines, the person has to be informed of the state of the art and the applicable national, European and international laws, directives and standards.

It is the company's responsibility only to employ personnel who

- ▶ Are familiar with the basic regulations concerning health and safety / accident prevention,
- ▶ Have read and understood the information provided in the section entitled Safety
- ▶ Have a good knowledge of the generic and specialist standards applicable to the specific application.

### Warranty and liability

All claims to warranty and liability will be rendered invalid if

- ▶ The product was used contrary to the purpose for which it is intended,
- ▶ Damage can be attributed to not having followed the guidelines in the manual,
- ▶ Operating personnel are not suitably qualified,
- ▶ Any type of modification has been made (e.g. exchanging components on the PCB boards, soldering work etc.).

### Disposal

- ▶ When decommissioning, please comply with local regulations regarding the disposal of electronic devices (e.g. Electrical and Electronic Equipment Act).

## Security

To secure plants, systems, machines and networks against cyberthreats it is necessary to implement (and continuously maintain) an overall industrial security concept that is state of the art.

Perform a risk assessment in accordance with VDI/VDE 2182 or IEC 62443-3-2 and plan the security measures with care. If necessary, seek advice from Pilz Customer Support.

### Implemented security measures

- ▶ The web application is protected against unauthorised access by a password prompt.
- ▶ The password is saved in an encrypted format.
- ▶ If a password is changed, you will be prompted to enter the old password for authentication.
- ▶ A user will automatically be logged out of the web application after a session duration of 24 hours.
- ▶ Defend against CSRF attacks by assigning a unique token to a session.

### Required security measures

- ▶ The product is not protected from physical manipulation or from reading of memory contents during physical access. We therefore recommend that you install the product in a lockable control cabinet.
- ▶ The computer that accesses the product has to be protected from attacks by a firewall or other suitable measures. We recommend that a virus scanner is used on this computer and updated regularly.
- ▶ Ensure that the product is separated by a router (layer 3 switch or firewall) from the company network.

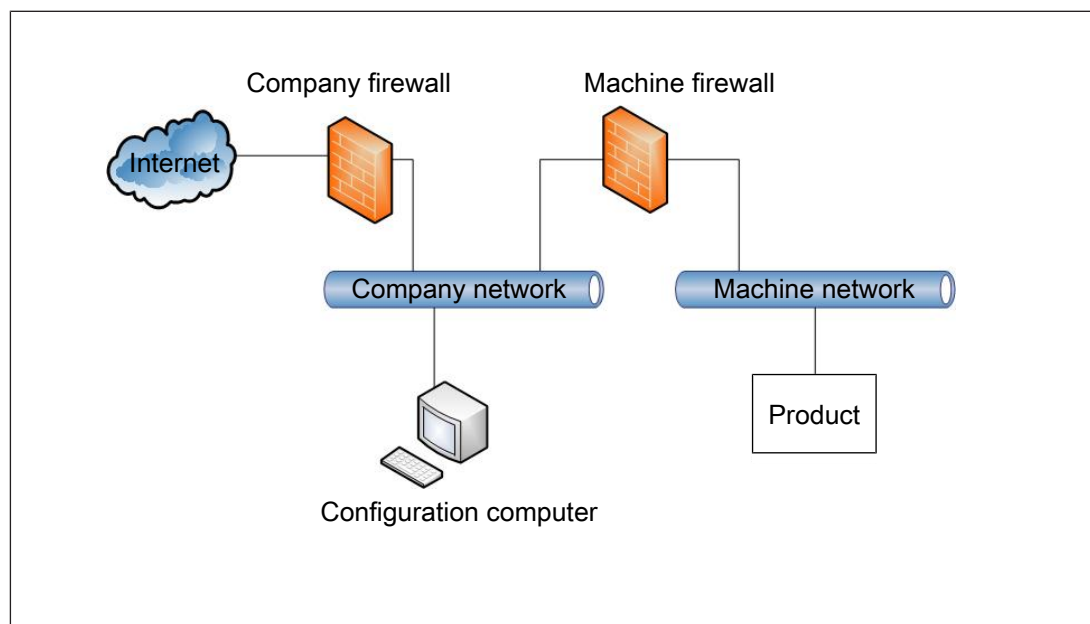

Fig.: Example network topology

- ▶ If necessary, protect the computer and the product from unauthorised use by assigning passwords and taking further measures if required. We also recommend that the logged in user does not have administrator rights.

- ▶ Assign only safe passwords. When assigning passwords, please note:
  - The password should have at least 8 characters.
  - The password should contain upper and lower case characters, as well as special characters and numbers.
  - If possible, the password should not be available in dictionaries.
  - The password should not be made up of standard variants and repetitions or keyboard patterns (so not: 1234abcd).
  - Use a password manager for optimum management of complex passwords.
  - Language-independent characters are not available in every keyboard language.
  - Make sure you regularly change the passwords of the user accounts on the system and/or ask the users to change their passwords themselves.
  - Make the users aware of the responsible use of their access data.
- ▶ Assign different permissions for the various user groups (e.g. diagnostics - configuration).
- ▶ Modbus/TCP has no security mechanisms. Use a firewall to protect the product from unauthorised access.
- ▶ As soon as possible, install firmware updates that Pilz provides for the product.
- ▶ Before disposal, the product must be safely decommissioned. To do this, all the data must be deleted from the device.
  - Set the configuration back to its default settings or delete the configuration.
  - Switch off the product.
- ▶ Note the network data for risk analysis and the security measures.

## Function description

### Operation

The SDD ES ETH is configured and started automatically after the supply voltage is switched on.

LEDs indicate the status of the SDD ES ETH and communication between the safety devices and Modbus/TCP Client.

The SDD ES ETH sends telegrams to the connected safety devices via a ring protocol.

The following types of data are transferred to the fieldbus and read in.

- ▶ Process data
  - Information and commands on safety functions (OSSD, guard locking, ...)
- ▶ Device data
  - Material number, serial number, product version, actuator ID, ...

► Configuration data

- Behaviour of the control of safety devices with guard locking (control of the guard locking via SDD can be switched on and off on PROFINET, EtherNET/IP and ETH using Autoinit)

Communication with connected control systems or control elements is via the bus interface Modbus/TCP.

The IP address is set on the display with the multifunction switch.

### Data structure

The input and output data is divided into the following data areas:

- Data for the overall system and for the SDD ES ETH
- Data for the connected safety devices
- List of specified changes of state and events
- Control system telegrams for the safety devices and responses from the safety devices

The data structure, including a list of the possible events, is described in detail in the System Description "Safety Device Diagnostics".

The messages are described in [Events of Safety Device Diagnostics](#) [📖 28].

### Block diagram

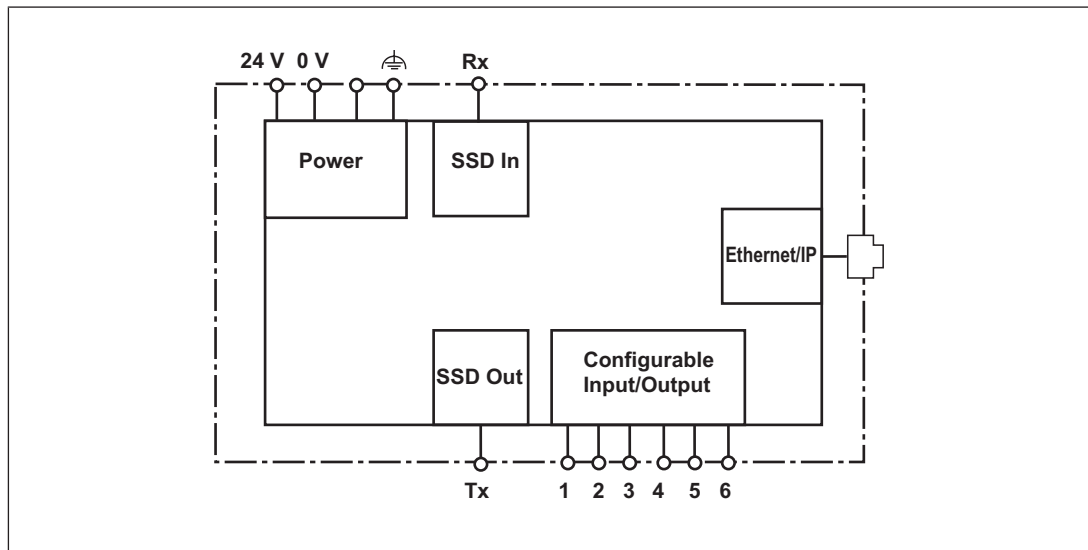

## Installation

- ▶ The safety relay should be installed in a control cabinet with a protection type of at least IP54.
- ▶ Use the notch on the rear of the unit to attach it to a DIN rail (35 mm).
- ▶ When installed vertically: Secure the unit by using a fixing element (e.g. retaining bracket or end angle).
- ▶ Push the device upwards or downwards before lifting it from the DIN rail.



### NOTICE



Damage due to electrostatic discharge!

Electrostatic discharge can damage components. Ensure against discharge before touching the product, e.g. by touching an earthed, conductive surface or by wearing an earthed armband.

## Commissioning

### General wiring guidelines

Please note:

- ▶ Information given in the [Technical details](#)  [32](#) must be followed.
- ▶ Use copper wiring with a temperature stability of 75 °C.
- ▶ External measures must be used to connect the  terminal to the functional earth.
- ▶ The device must be supplied from the same power supply as the connected safety devices.
- ▶ The power supply must meet the regulations for extra low voltages with protective electrical separation (SELV, PELV).

### Ethernet interfaces

#### RJ45 interfaces ("Ethernet")

Two free switch ports are provided as Ethernet interfaces via an internal autosensing switch. The autosensing switch automatically detects whether data transfer is occurring at 10 Mbit/s or 100 Mbit/s.



### INFORMATION

The connected subscribers must support the autosensing/autonegotiation function. If not, the communication partner must be set permanently to "10 Mbit/s, half duplex".

The switch's automatic crossover function means there is no need to distinguish on the connection cable between patch cable (uncrossed data line connection) and crossover cable (crossover data line connection). The switch automatically creates the correct data line connection internally. Patch cable can therefore be used as the connection cable for end devices as well as cascading.

Both Ethernet interfaces use RJ45 technology.

**Requirements of the connection cable and connector**

The following minimum requirements must be met:

- ▶ Ethernet standards (min. Category 5) 10BaseT or 100BaseTX
- ▶ Double-shielded twisted pair cable for industrial Ethernet use
- ▶ Shielded RJ45 connectors (industrial connectors)

**Interface configuration**

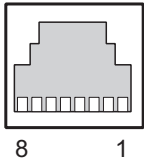
RJ45 socket 8-pin	PIN	Standard	Crossover
	1	TD+ (Transmit+)	RD+ (Receive+)
	2	TD- (Transmit-)	RD- (Receive-)
	3	RD+ (Receive+)	TD+ (Transmit+)
	4	n.c.	n.c.
	5	n.c.	n.c.
	6	RD- (Receive-)	TD- (Transmit-)
	7	n.c.	n.c.
	8	n.c.	n.c.

**RJ45 connection cable**

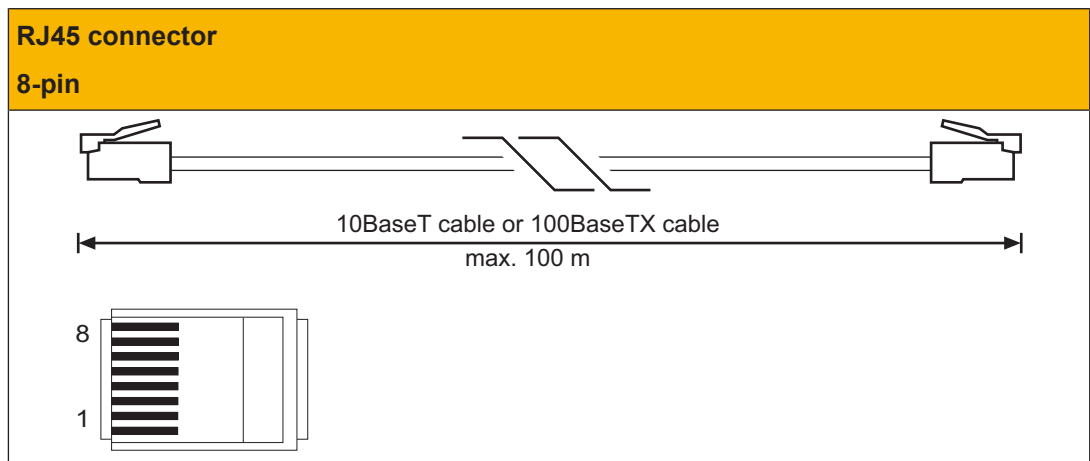

**NOTICE**

With the plug-in connection please note that the data cable and connector have a limited mechanical load capacity. Appropriate design measures should be used to ensure that the plug-in connection is insensitive to increased mechanical stress (e.g. through shock, vibration). Such measures include fixed routing with strain relief, for example.

**Process data exchange**

The RJ45 interfaces on the internal autosensing switch enable process data to be exchanged with other Ethernet subscribers within a network.

The product SDD ES ETH can also be connected to Ethernet via a hub (hub or switch).

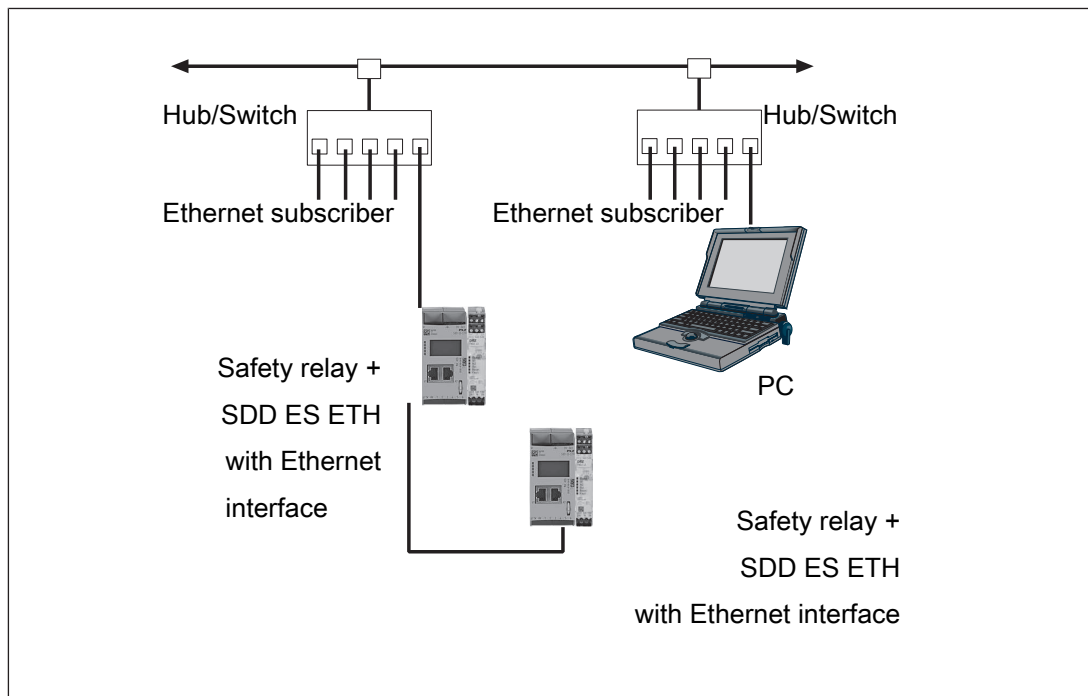

## System structure

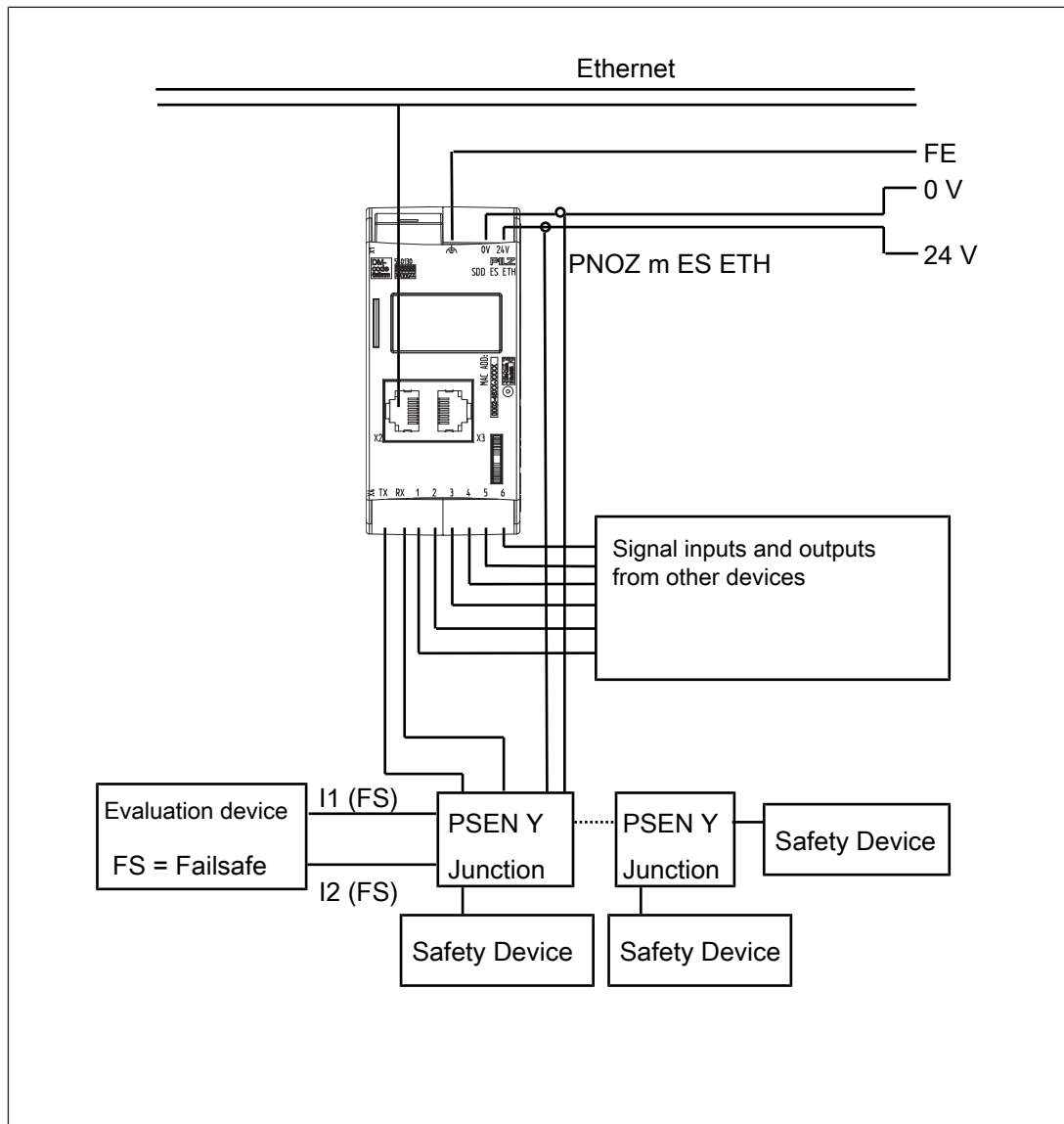

### Set IP address

When setting the IP address, please note:

- ▶ The IP address for the fieldbus module SDD ES ETH should not be the same as the PC's IP address.

The following different options are available for setting the IP address.

### Obtain IP address automatically via DHCP Server

The IP address can be assigned automatically via a DHCP Server

In order to do this, DHCP must be activated on the fieldbus module SDD ES ETH.

- ▶ DHCP is already activated when the module is delivered. The IP address is obtained automatically from the DHCP server. The module waits to receive an address from a DHCP Server.

### Setting the IP address via the web server



For details of how to set the IP address via the implemented web server, refer to the section entitled [Web server \[23\]](#).











If a fixed IP address has been assigned via the web server, then this will be used.

### Operation

The SDD ES ETH is ready for operation when the "Power" LED is lit and the "Fault" LED is unlit.

#### Legend

-  LED on
-  LED flashes
-  LED off

LED	State		Meaning / action
Power			Supply voltage is outside the permitted range (see <a href="#">Technical details [32]</a> )
		Green	Supply voltage is present
ModbusTCP			No access via the bus connection
		Green	Access via the bus connection
Devices		Green	All connected devices are enabled
			At least one connected device is not enabled
Start up			Normal operation
		Yellow	Device data is being polled
Fault			Normal operation
		Red	Fault on the SDD ES ETH. Check the supply voltage, wiring and configuration of the SDD ES ETH.  The system continues to attempt to poll the connected sensors and to create a full list of the connected sensors. In the web interface, therefore, the status in <b>Device Info</b> alternately displays "Initializing" and a yellow status bar, or "Error Handling" and a red status bar.
			Internal fault on the SDD ES ETH Remedy: Replace the device

## Display

### Structure

The LC display has five lines. Information can be shown and settings can be made on the display.

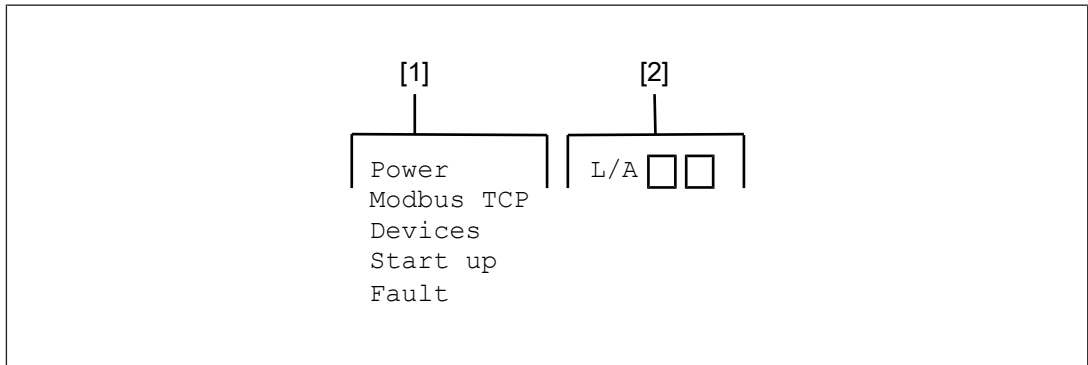

### Legend

[1] LED indicators

[2] Status of the bus connection, operating options in the menus

Information on the connection and instructions for the menu settings are displayed in the field in the top right of the display:

Display	Meaning
L/A [ ] [ ]	Status of bus connection: No connection

Press the multifunction switch to switch to the first menu level.

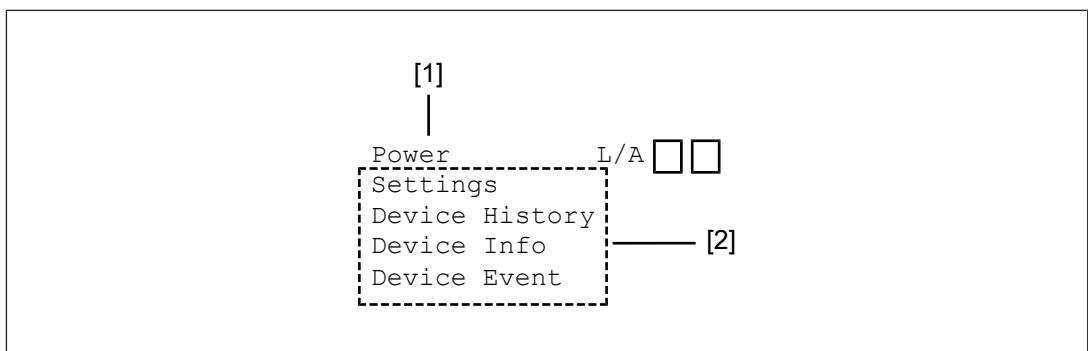

### Legend

[1] Display of LED supply voltage

[2] Display of menu levels

### Operate menu

The menu settings are made on the device's display via a multifunction switch. You can switch between the menu levels by pressing or rotating the multifunction switch.

#### Press multifunction switch



- ▶ Confirm selection/setting
- ▶ Switch to sub-menu
- ▶ Exit menu: <- **Back**

#### Rotate multifunction switch up or down



- ▶ Switch menu entries or display potential values

### Menu structure

The LC display has a max. five lines.

It displays information and navigates the menu.

The status of the supply voltage is displayed in the first line, followed by 4 lines containing the menu levels.

Menu	Description
Settings	Information about I/O mapping on the connected safety devices and about the network configuration of the SDD ES ETH
Device History	Information about previous changes of state (enables and guard locking) of a connected safety device and status information
Device Info	Information about the connected safety devices
Device Event	Message on the change of state of a safety device

## Menu settings

### GPIO-Mapping

Value range	Meaning
PLC	Value is set by control system
1-16	1-16 represents a connected safety device. If the actuator enable is set for this safety device, the GPIO is set to 24 V.  If the value $\neq$ PLC, the control system has no access to the input/output channel.

### IP Config.

Option	Value range	Meaning
DHCP	On / Off	DHCP status (status when delivered = On) Changes will only take effect when SDD ES ETH is restarted.
IP Address	xxx.xxx.xxx.xxx	Display or change the set IP address (xxx = 1 to 255) Changes will only take effect when SDD ES ETH is restarted.
Netmask	255.255.255.xxx	Display or change the set subnet mask Changes will only take effect when SDD ES ETH is restarted.
Gateway Addr.	xxx.xxx.xxx.xxx	Display or change the set Gateway address Changes will only take effect when SDD ES ETH is restarted.
Restart		Trigger a restart of the SDD ES ETH in order to adopt the amended IP configuration settings.

### Info

Option	Meaning
IP Address:	Current IP address setting
Ver:	Product version
SVN:	Software version
SN:	Serial number of safety device

## Reset Passwords

Option	Meaning
Confirm Reset No Yes	The password for the Settings area can be reset to the password supplied when delivered. <ul style="list-style-type: none"> <li>▶ Select Yes to reset the password</li> <li>▶ Select No to retain the password</li> </ul>

## Lock Autoinit

Option	Meaning
	Options for the control of the guard locking activation. The setting can also be made via a fieldbus register.
Set to No	Guard locking activation up to the first command via fieldbus using safety outputs of the safety control system
Set to Yes	Guard locking activation only via Safety Device Diagnostics

## Device History menu

## Device History

Option	Value range	Meaning
Status		Display of message number. The message number is incremented up to 150. Then the oldest messages are overwritten. All message numbers are deleted by switching off the supply voltage.
Device	1-16	Number of device
Safety Gate	◆	Actuator is within the response range
	◇	Actuator is not within the response range
⌚ in sec		Time at which the safety gate was opened (seconds since power-on)
Lock	◆	Guard locking activation
	◇	Guard locking activation

## Device Info menu

### Device Info

Option	Value range	Meaning
◆ ◆		Number of safety devices (Safety Gate) = Number of diamonds represented State of safety devices (Safety Gate enable):
	◆	Ready
	◇	Not available
◆ ◆		Number of safety devices (guard locking) = Number of diamonds represented State of the safety devices (guard locking):
	◆	activated
	◇	deactivated
I/O	◆◆◆◆◆	State of the configurable inputs/outputs
Device n/x	1/1 – 16/16	Device n of x connected devices

### Device n/x

Option	Value range	Meaning
xxx	Max. 16 characters (letters, numbers and special characters)	Equipment identifier (on a fieldbus module with web server)
Coded Switch	e.g. coded switch	Information about device type <sup>(*)</sup>
Ready	◆ / ◇	Status of safety device
		◆ Ready
		◇ Not available
Safety Gate	◆ / ◇	Status of safety gate
		◆ Actuator within the response range
		◇ Actuator not within the response range
Lock	◆ / ◇	Status of guard locking
		◆ activated
		◇ deactivated
OSSD1	◆ / ◇	Status of OSSD1
		◆ ON state
		◇ OFF state
OSSD2	◆ / ◇	Status of OSSD2
		◆ ON state
		◇ OFF state
INPUT1	◆ / ◇	Status Input 1

Option	Value range	Meaning
INPUT2	◆ / ◇	Status Input 2
Coding	C, F, U	Pilz coding type <sup>(*)</sup> C = coded, F = fully coded, U = uniquely fully coded
TeachIn free	1-8	Number of teach-in processes remaining <sup>(*)</sup>
Temp °C		Temperature of a safety device in °C. The temperature of one safety device is updated every two minutes; with 16 safety devices, for example, the temperature of the first safety device is updated every 32 minutes.
Act.#		Actuator short name
Ident#		Material number of safety device <sup>(*)</sup>
SN#		Serial number of safety device <sup>(*)</sup>

<sup>(\*)</sup> Value on restart

### Device Event menu

Device Event

Option	Meaning
Event Nr. x	Display of consecutive event numbers (event number is incremented up to 150 and then the oldest number is overwritten)
Device x	Number of device
Message # x	Display of a message or message number (the messages are described in detail under <a href="#">Messages for safety device diagnostics</a> [  28])

### Web server

A web server is implemented in the fieldbus module SDD ES ETH. This can be used to poll data from the SDD.

- ▶ The web server is started once the SDD ES ETH is connected to the supply voltage.
- ▶ The web server is intended for use with Internet Explorer or Firefox.
- ▶ Make sure that Javascript and Cookies are enabled in your browser's security settings.

### Start of the web server

1. Connect the SDD ES ETH to the PC.
2. Call up the HTML page:
  - **http://192.168.0.xxx**
  - For xxx, enter the value that you have set as the last byte of the IP address.
3. Enter the user name and password correctly and log on to the web application.
4. Select the option you require in the overview and then follow the instructions.

**Device History**

The last 23 messages since the SDD ES ETH was switched on are displayed.

The messages are described in the System Description "Safety Device Diagnostics".

Updated by reload: this page is updated by reloading the page in the browser.

**Device Info**

The information available about the connected safety devices on the SDD ES ETH is displayed.

Updated automatically: this page is updated automatically every second.

Column name	Value range	Meaning
Device Info		Status of the SDD ES ETH
Devices	1-16	Number of connected safety devices
Safety Gate	Green = closed Grey = open	Status of the connected safety devices without guard locking
Lock	Green = activated Grey = deactivated	Status of the connected guard locking devices
OSSD 1&2	Green = closed Grey = open	Status of the connected OSSD
I/O		Value that is read in at the GPIOs
Time in sec		Time in seconds since power-up (jumps back to 0 after 65535 seconds)

**Device Event**

Display of events that have occurred. The last 23 entries are displayed.

The data is stored in a permanent memory and so is still available after the supply voltage is switched back on.

The event number is displayed for each event, along with max. 3 additional lines with further details. The events are described in detail in [Messages for safety device diagnostics](#) [28].

Updated by reload: this page is updated by reloading the page in the browser.

**Device xx**



Option	Value range	Meaning	
Coded Switch	e.g. Coded Switch	Information about device type	
Device Info	◆ / ◇	Status of safety device (updated automatically)	
		◆	Ready
		◇	Not available

Option	Value range	Meaning	
Safety Gate	◆ / ◇	Status of safety gate	
		◆	Actuator within the response range
		◇	Actuator not within the response range
Lock	◆ / ◇	Status of guard locking	
		◆	activated
		◇	deactivated
OSSD 1&2	◆ / ◇	Status OSSD1 & 2 (updated automatically)	
		◆	closed
		◇	open
SN#		Serial number of safety device	
Ident#		Material number of safety device	
Actuator#		Short name of the actuator (updated automatically)	
Device Type	C, F, U	Pilz coding type C = coded F = fully coded U = uniquely fully coded	
Teach In Free	1-8	Number of teach-in processes remaining	
Temperature in °C		Temperature in °C	

Updated by reload: this page is updated by reloading the page in the browser.

### Settings

The following options are available under **Settings**:

- ▶ [Manage equipment identifier for the connected safety devices](#)  26]
- ▶ [Set and store GPIO values](#)  26]
- ▶ Manage password for the range **Settings** (see [Set new Password](#)  26])

This is the preset login data when the device is delivered:

- User = User
- Password = 1111

Once logged in, you can log out again with logout. Logout occurs automatically when the SDD ES ETH is restarted or the browser is closed.

- ▶ Delete the list of events (see [Delete Events](#)  26])
- ▶ The **Settings** area can be used by 2 users simultaneously.
- ▶ **Download data**

The values in the areas [Settings](#), [Device Info](#), [Device History](#) and [Device Event](#) can be exported by clicking [Download](#) and saving the displayed content.

**Setting**

A name can be assigned to the safety device in Value.

	<b>Value range in the Value field</b>	<b>Status</b>
<b>Equipment Identifier xx</b>	Max. 16 characters (letters, numbers and special characters)	Status of change <b>Saved</b> = Change was stored and adopted

**GPIO**

The current values at the GPIO are displayed and can be changed.

If the value is changed, select the new value in the value list.

▶ **Save changes**

Changes can be saved using **Save Settings**. Once saved, the change is visible immediately in the display of the SDD ES ETH.

▶ **Export settings**

The current setting can be saved as an HTML file.

Click on **Export Settings**. A **DOWNLOAD LINK** is displayed. Right-click on **DOWNLOAD LINK** and save the file.

▶ **Import settings**

Saved settings can be imported.

Click on **Import Settings** and select an HTML file with settings. The imported settings must be saved using **Save Settings** in order for them to take effect.

**Delete Events**

▶ **Delete Events**

The list of events can be deleted.

– Click on **Delete**.

– **All Events will be deleted please confirm** is displayed

Click **OK** to delete all previous events.

Click **Abort** if no events are to be deleted.

**Set new Password**

A new password should be set after the SDD ES ETH is switched on for the first time.

▶ Enter the old password in the **Old Password** field and enter the new password in the **New Password** field.

Enter the new password again under **Confirm new Password** and click on **Set Password**.

### **Firmware update**

The firmware and the web server of SDD ES ETH can be updated.

1. Set the IP address of the configuration PC to the address range of the SDD ES ETH (e.g. 192.168.0.1).

To access SDD ES ETH, the IP address of the PC has to be in the same subnet as the IP address of SDD ES ETH

Change the IP address in the network settings of your configuration PC or change the IP address of the SDD ES ETH (see Set IP address).

2. Establish an FTP connection to the Gateway, using the user name "Admin" and password "0000".
3. Copy the file "SDD\_xxx.kfu" and the directory "web" with FTP to the SDD ES ETH and save the files in the topmost directory.
4. Perform a [restart](#) [ 20] of SDD ES ETH. The changed configuration is therefore adopted.

## Events of Safety Device Diagnostics

Number	Output text	Meaning/action
0x300	Safety Gate!	The actuator has changed state quickly. <ul style="list-style-type: none"> <li>▶ Check and correct the misalignment of switch and actuator and correct if necessary.</li> </ul>
0x301	Input ≠	Safety device in partially operated status <ul style="list-style-type: none"> <li>▶ Check the wiring.</li> </ul>
0x302	Input ≠, Restart	Safety device in partial operation lock status <ul style="list-style-type: none"> <li>▶ Check the wiring and switch the voltage off and then on again.</li> </ul>
0x303	Power ↑, please ↓	Supply voltage is at the upper limit of the permitted range (see Technical details for safety device) <ul style="list-style-type: none"> <li>▶ Ensure the supply voltage corresponds to the Technical details for the connected safety device.</li> </ul>
0x304	Power ↓, please ↑	Supply voltage is at the lower limit of the permitted range (see Technical details for safety device) <ul style="list-style-type: none"> <li>▶ Ensure the supply voltage corresponds to the Technical details for the connected safety device.</li> </ul>
0x305	Actuator ≠	Wrong actuator signalled on unique or fully coded versions of a safety device <ul style="list-style-type: none"> <li>▶ Use the actuator stated in the operating manual for the safety device.</li> </ul>
0x306	Actuator ♥	New actuator has been taught in <ul style="list-style-type: none"> <li>▶ Switch supply voltage off and then on again.</li> </ul>
0x320	Lock ≠	Guard locking could not be activated or deactivated. <ul style="list-style-type: none"> <li>▶ Check the wiring of the control and the actuator.</li> </ul>

Number	Output text	Meaning/action
0x321	Lock $\#$	Guard locking is in a not defined position. <ul style="list-style-type: none"> <li>▶ Use the escape release to move the guard locking into the open state.</li> </ul> Switch the voltage off and then on again
0x900 0x901	**Start UP**	Fieldbus module and communication with the safety devices have been restarted
0x902	Chain $\#$	Open circuit <ul style="list-style-type: none"> <li>▶ Without stated safety device: Connection from and to the fieldbus module has been interrupted</li> <li>▶ With stated safety device: Connection before the stated device has been interrupted</li> </ul> Check the wiring and switch the voltage off and then on again.
0x903	Please $\leftrightarrow$ Device	Internal error <ul style="list-style-type: none"> <li>▶ Change the safety device.</li> </ul>
0x904	Please Reset	Internal error <ul style="list-style-type: none"> <li>▶ Check the wiring and switch the voltage off and then on again.</li> </ul>
0x905	OSSD 1&2 $\#$	Fault on the safety device output <ul style="list-style-type: none"> <li>▶ Check the wiring and switch the voltage off and then on again.</li> </ul>
0x906	OSSD 1 $\#$	Fault on the safety device OSSD1 output <ul style="list-style-type: none"> <li>▶ Check the wiring and switch the voltage off and then on again.</li> </ul>
0x907	OSSD 2 $\#$	Fault on the safety device OSSD2 output <ul style="list-style-type: none"> <li>▶ Check the wiring and switch the voltage off and then on again.</li> </ul>
0x908	Power $\uparrow$ , please $\downarrow$	Supply voltage above the permitted range (see Technical details for safety device) <ul style="list-style-type: none"> <li>▶ Reduce the supply voltage.</li> </ul>

Number	Output text	Meaning/action
0x909	Power ↓, please ↑	Supply voltage below the permitted range (see Technical details for safety device) ▶ Increase the supply voltage.
0x90A	Escape Release	The escape release was operated. ▶ Reset the safety device to normal operation.

### Dimensions in mm

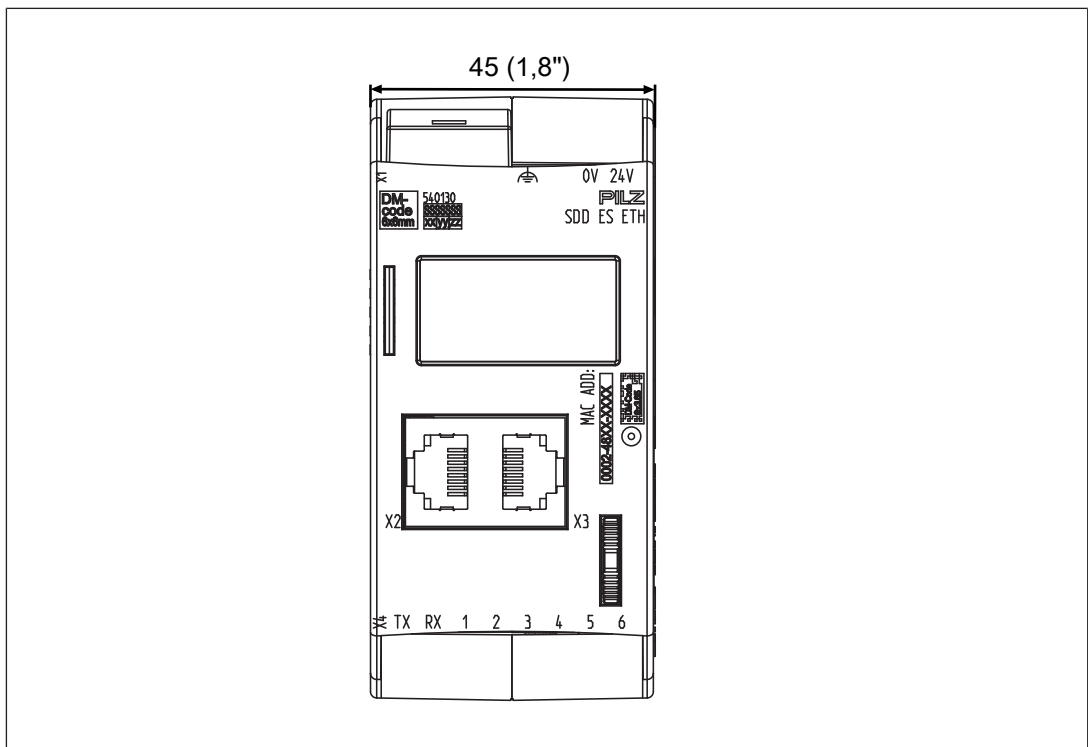

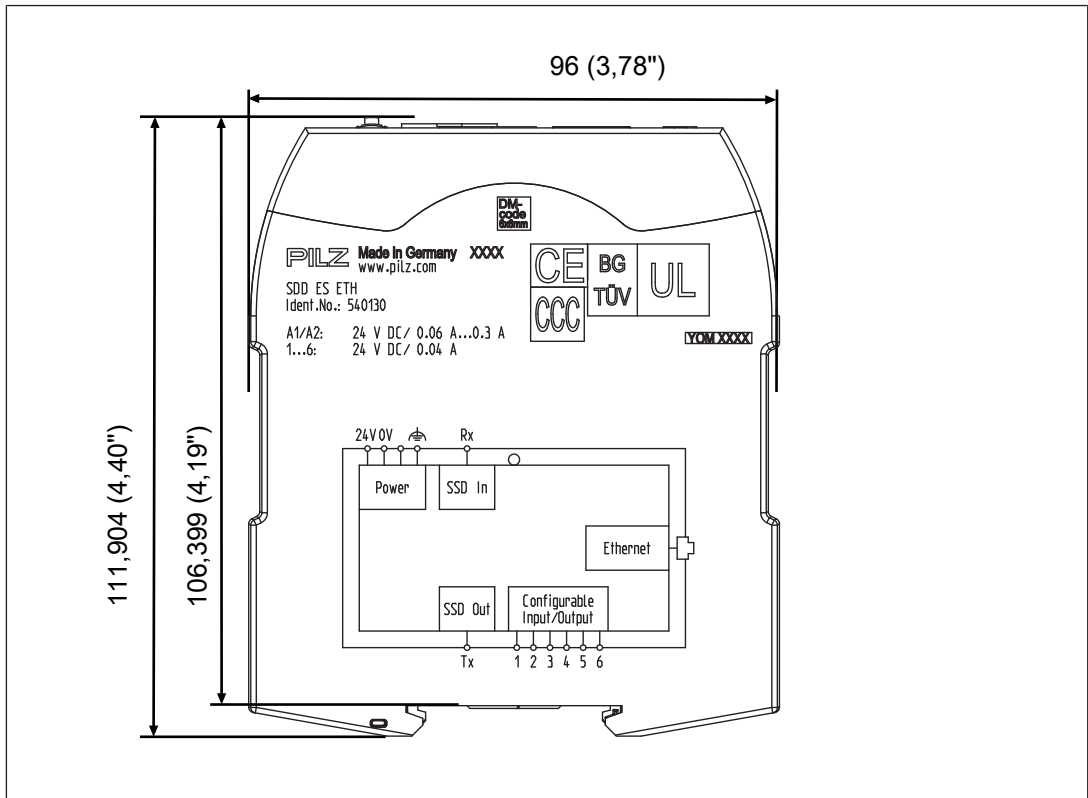

## Technical details

General	
Certifications	CE, cULus Listed
Electrical data	
Supply voltage	
for	<b>Module supply</b>
Voltage	<b>24 V</b>
Kind	<b>DC</b>
Output of external power supply (DC)	<b>2 W</b>
Status indicator	<b>Display, LED</b>
Inputs	
Number	<b>6</b>
Semiconductor outputs	
Number	<b>6</b>
Short circuit-proof	<b>yes</b>
Semiconductor outputs (standard)	
Switching capability	
Voltage	<b>24 V</b>
Current	<b>0,04 A</b>
Power	<b>1 W</b>
Fieldbus interface	
Fieldbus interface	<b>Modbus/TCP</b>
Log	<b>Modbus TCP (Slave)</b>
Station address	<b>0 - 255d</b>
Maximum data length of fieldbus interface	
Input device	<b>512 Byte</b>
Output	<b>512 Byte</b>
Input/output combined	<b>512 Byte</b>
Transmission rates	<b>10 MBit/s, 100 MBit/s</b>
Connection	<b>RJ45</b>
Galvanic isolation	<b>yes</b>
Type of galvan. isolation	<b>Functional insulation</b>
MODBUS	
Number of MODBUS connections	<b>8</b>
Connection type	<b>RJ45</b>
Device type	<b>Server</b>
Permitted address range MODBUS/TCP port	<b>1 - 65535</b>
Operating mode	<b>Auto-MDIX, Autonegotiation</b>
Default port MODBUS/TCP	<b>502</b>
Transmission rates	<b>10 MBit/s, 100 MBit/s</b>
Galvanic isolation	<b>yes</b>
Times	
Supply interruption before de-energisation	<b>20 ms</b>

<b>Times</b>	
Default value, keep-alive time	<b>32000 ms</b>
<b>Environmental data</b>	
Ambient temperature	
In accordance with the standard	<b>EN 60068-2-14</b>
Temperature range	<b>0 - 55 °C</b>
Storage temperature	
In accordance with the standard	<b>EN 60068-2-1/-2</b>
Temperature range	<b>-25 - 70 °C</b>
Climatic suitability	
In accordance with the standard	<b>EN 60068-2-30, EN 60068-2-78</b>
Humidity	<b>90 % r. h. at 55 °C</b>
Condensation during operation	<b>Not permitted</b>
Max. operating height above sea level	<b>2000 m</b>
EMC	<b>EN 61000-4-3, EN 61000-4-5, EN 61000-4-6, EN 61000-6-4</b>
Vibration	
In accordance with the standard	<b>EN 60068-2-6</b>
Frequency	<b>5 - 150 Hz</b>
Acceleration	<b>1g</b>
Shock stress	
In accordance with the standard	<b>EN 60068-2-27</b>
Acceleration	<b>15g</b>
Duration	<b>11 ms</b>
Protection type	
In accordance with the standard	<b>EN 60529</b>
Housing	<b>IP20</b>
Terminals	<b>IP20</b>
Mounting area (e.g. control cabinet)	<b>IP54</b>
<b>Potential isolation</b>	
Potential isolation between	<b>Modbus and system voltage</b>
Type of potential isolation	<b>Functional insulation</b>
Rated surge voltage	<b>2500 V</b>
<b>Mechanical data</b>	
Mounting position	<b>Any</b>
DIN rail	
Top hat rail	<b>35 x 7,5 EN 50022</b>
Material	
Bottom	<b>PC</b>
Front	<b>PC</b>
Top	<b>PC</b>
Connection type	<b>Spring-loaded terminal, plug-in, screw terminal, plug-in</b>
Conductor cross section with screw terminals	
1 core flexible	<b>0,25 - 2,5 mm<sup>2</sup>, 24 - 12 AWG</b>

**Mechanical data**

## Dimensions

Height **115 mm**Width **45 mm**Depth **95 mm**Weight **160 g**

Where standards are undated, the 2016-02 latest editions shall apply.

**Supplementary data****Network data**

Interface	Protocol	Direction	Transport log	Port No.	Can be de-activated	Description
User interface	HTTP	In	TCP	80	No	Browser, web interface
File Transfer	FTP	in/out	TCP/IP	21	No	FTP connection for firmware updates
DHCP	BOOTP	in/out	UDP	67 68	Yes	Automatic receipt of a network address
Modbus	Modbus/TCP	in/out	TCP/IP	502	No	Data exchange via Modbus/TCP connection

**Order reference****Product**

Product type	Features	Order no.
SDD ES ETH	Fieldbus module ETH for Safety Device Diagnostics	540 130

**Accessories**

Product type	Features	Order no.
SDD ES SET SCREW TERMINALS	Screw terminals, plug-in	540 120
SDD ES SET SPRING LOADED TERMINALS	Spring-loaded terminals, plug-in	540 121

Product type	Features	Connector X1	Connector X2	Connector X3	Order no.
PSEN Y junction M12 SENSOR		M12, 8-pin male connector	M12, 8-pin fe- male connector	M12, 8-pin fe- male connector	540 315
PSEN Y junction M12 cable channel		M12, 8-pin male connector	M12, 8-pin fe- male connector	M12, 8-pin fe- male connector	540 316
PSEN T junction (auxiliary contact) M12		M12, 8-pin fe- male connector	M12, 8-pin male connector	M8, 4-pin male connector	540 331
PSEN Y junction M8-M12/M12 PIG- TAIL	Cable separ- ator for PSEN- code, PSENS- lock	M12, 8-pin fe- male connector	M12, 8-pin male connector	M8, 8-pin male connector	540 337
PSEN Y junction M12-M12/M12 PIG- TAIL	Cable separ- ator for PSEN- code, PSENS- lock	M12, 8-pin male connector	M12, 8-pin fe- male connector	M8, 8-pin fe- male connector	540 338
PSEN ml Y junction M12		M12, 8-pin male connector	M12, 8-pin fe- male connector	M12, 12-pin fe- male connector	570 486
PSEN ml / PSENcs Y junction M12		M12, 8-pin fe- male connector	M12, 8-pin male connector	M12, 8-pin fe- male connector	570 489

### EC declaration of conformity

This/(These) product(s) fulfil the requirements of the low voltage directive 2006/95/EG. The complete EC Declaration of Conformity is available on the Internet at [www.pilz.com/downloads](http://www.pilz.com/downloads).

Representative: Norbert Fröhlich, Pilz GmbH & Co. KG, Felix-Wankel-Str. 2, 73760 Ostfildern, Germany